

ORBITAL-GENIE™

BENCHTOP ORBITAL SHAKER

OPERATING INSTRUCTIONS

Models SI-I 500 through SI-I 706



70 Orville Drive, Bohemia, NY 11716 U.S.A.
Phone: (631) 567-4700 • Fax: (631) 567-5896 Toll Free: 888-850-6208
Customer Service: custsvc@scientificindustries.com
www.scientificindustries.com

The **ORBITAL-GENIE™** is a large capacity, multi vessel orbital shaker. Speed and time are digitally controlled for reproducibility and accuracy, with true speed display.

OPERATING INSTRUCTIONS

We recommend you retain the original packaging for 90 days in case you need to return the product for any reason to your distributor or Scientific Industries.

Plug the line cord into a properly grounded electrical outlet. (**120 VAC for the SI-1500, SI-1600 and SI-1700 models; 220-240 VAC for the SI-1501, SI-1502, SI-1503, SI-1504, SI-1506, SI-1601, SI-1602, SI-1603, SI-1604, SI-1606, SI-1701, SI-1702, SI-1703, SI-1704 and SI-1706 models; 100 VAC for the SI-1506, SI-1606 and SI-1706 models**).

Illuminated numbers will appear in the TIME and SPEED windows indicating that the unit is ON and ready for use.

The work surface on which the shaker is placed must be level, stable and non-slip.

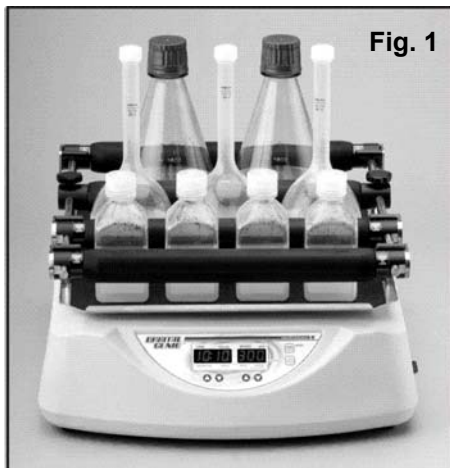

Fig. 1



Fig. 2

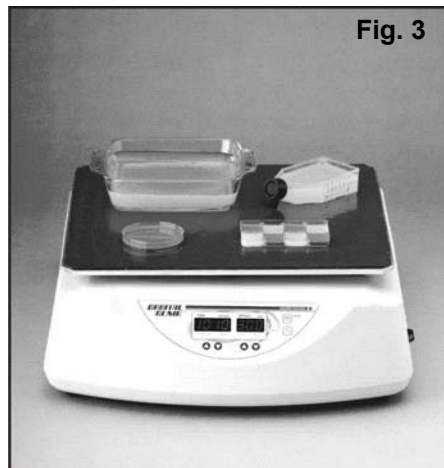

Fig. 3

ORBITAL-GENIE™ with Universal Ratcheting Clamps (SI-1500)

The shaker is supplied with two ratcheting and one non-ratcheting cushioned clamps (Fig.1, shown with additional ratcheting clamp). The non-ratcheting clamp acts as a stationary stop for securing the vessels. It should be located at the far end or middle of the platform rods and locked in place with the thumbscrews. Position the two ratcheting clamps on the platform rods with sufficient space to fit the vessels. Place the vessels so that they do not touch each other and are seated firmly against the non-ratcheting clamp. Position vessels evenly distributed on the platform. Uneven loading may result in excessive vibrating of the shaker and support table. Should this occur, reduce the speed or turn the shaker off and redistribute the vessels. The clamping platform can accommodate 250mL – 2 liter vessels with a 26 lbs load capacity. It is very important to regularly monitor shaking cycles to ensure that the vessels remain firmly secure. Press the ratcheting clamps until the foam is compressed against the vessels (Fig.4). To release the ratcheting clamps, pull the release arm and slide away (Fig.5).

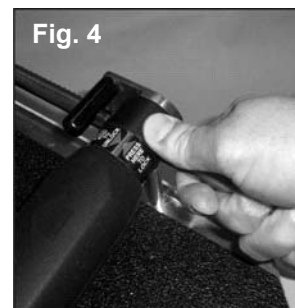

Fig. 4

ORBITAL-GENIE™ for Standard Flask Clamps (SI-1600)

The shaker is supplied with a platform for accepting various size flasks or beakers (Fig.2). Flask clamps attach to the platform with captive mounting screws. Flask clamps are sold separately. Position clamps evenly distributed on the platform. Uneven loading may result in excessive vibrating of the shaker and support table. Should this occur, reduce the mixing speed or turn the shaker off and redistribute the load of the vessels.

ORBITAL-GENIE™ with Adhering Mat (SI-1700)

The shaker is supplied with an adhering rubber mat for use with bottles and dishes that cannot be held with conventional clamps (Fig.3). Patented material is naturally adhering. Rinse clean to renew adhering properties. Flask clamps can be used on this unit by removing the adhering mat.

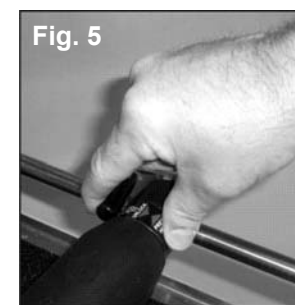

Fig. 5

OPERATION

Power on the **ORBITAL-GENIE™** (rocker switch on lower right side of housing). The software version number will briefly be shown on the display. After 5 seconds the display will show time and speed settings.

TIME

Time is displayed in the left window. Press the UP/DOWN arrow button beneath the TIME window to set the desired cycle time from 1 minute to 99 hours 59 minutes. Press the RUN/STOP button to begin the shaking action. The shaker will ramp up to speed and run until the set time has elapsed. Upon time elapse, an alarm will beep every 15 seconds and the TIME set value will blink. Beeping will end after 5 minutes but the TIME display will continue to blink. Press any button to exit the cycle end state.



Fig. 6

NON-TIMED (CONTINUOUS)

Press and hold the DOWN arrow button beneath the TIME window until the illuminated display reaches “00.00”. Press the RUN/STOP button to begin the shaking action. The timer will count up from 00.00 to 99.59 and then wrap back to 00.00.

SPEED

Set the speed control by pressing the UP/DOWN arrow beneath the SPEED window to any value between 10 RPM and 300 RPM.

REVERSING and ACCELERATION/DECELERATION

To modify the ACCELERATION/DECELERATION ramp speed and REVERSING TIME, press and hold the NORMAL/REVERSE button for 2 seconds. The TIME and SPEED displays will flash (Fig.7). The left display is reversing time. The right display is acceleration/deceleration rate. Use the UP/DOWN arrows on the left side to change the time between reversing (minutes and seconds – from one second to 99 minutes) and the arrows on the right side to change the acceleration/deceleration speed value from 10 to 100 RPM/SEC. The new value will be applied immediately and memorized upon key release. This mode (flashing) will be exited automatically after 10 seconds or by pressing the NORMAL/REVERSE button once. By modifying these values, you can change the nature of mixing action from smooth vortexing to sloshing aeration, or anything in between.



Fig. 7

REVERSE mode toggles the shaker between operating in only one direction, and switching directions at regular intervals. To initiate the REVERSE mode, press the NORMAL/REVERSE button. The REVERSE LED on the display will turn on (Fig.8). Press the RUN/STOP button to begin the mixing action.



Fig. 8

Please note that if you set acceleration to lower values, in combination with short reversing or cycle times, the unit will limit the maximum speed setting to values that are achievable (ie: reversing time of 5 seconds with acceleration/deceleration of 10 RPM/second – unit will only allow maximum speed of 25 RPM – 2.5 seconds of acceleration at 10 RPM/second and 2.5 seconds of deceleration at 10 RPM/second).

Also note that, for safety reasons, when pressing the RUN/STOP button to end a cycle (instead of letting the timer stop the unit), maximum deceleration (100RPM/second) is used .

In between shaking cycles, the platform can move freely. To lock the movement of the platform (for ease of loading vessels) press and hold the RUN/STOP button and simultaneously press the NORMAL/REVERSE button. The shaking platform will lock. See Fig. 9 for display readout. Initiating a shaking cycle will exit this mode.



Fig. 9

SPECIFICATIONS

The ORBITAL-GENIE™ Shaker is classified as “Installation Category 2”
Environmental: 0°C – 38°C (32°F-100°F), 95% Humidity max.

MODEL	POWER REQUIRED	AMPS	MODEL	POWER REQUIRED	AMPS
SI-1500	120V	2.0	SI-1703	230V British Plug	1.0
SI-1600	120V	2.0	SI-1504	230V Swiss Plug	1.0
SI-1700	120V	2.0	SI-1604	230V Swiss Plug	1.0
SI-1501	230V No Plug	1.0	SI-1704	230V Swiss Plug	1.0
SI-1601	230V No Plug	1.0	SI-1506	230V Australian Plug	1.0
SI-1701	230V No Plug	1.0	SI-1606	230V Australian Plug	1.0
SI-1502	230V Euro Plug	1.0	SI-1706	230V Australian Plug	1.0
SI-1602	230V Euro Plug	1.0	SI-1505	100V	2.5
SI-1702	230V Euro Plug	1.0	SI-1605	100V	2.5
SI-1503	230V British Plug	1.0	SI-1705	100V	2.5
SI-1603	230V British Plug	1.0			

Weight: 21 Kg (46 lbs)

Base Dimensions: (DxW) 590 x 500mm, (23 x 20in)

Orbit: 35mm diameter

Care and Handling

Your ORBITAL-GENIE™ Shaker should be given the care normally required for any electrical appliance. Avoid wetting or unnecessary exposure to fumes. The finish can be washed with water (after unplugging) and soap or detergents, using a cloth or sponge. Keep the unit clean by immediately blotting any spills. Replacement parts are available through your laboratory equipment distributor or directly from Scientific Industries. Refer to “Parts Assembly List”.

 **CAUTION! Do not lift your ORBITAL-GENIE™ Shaker by the clamping platform.**

 **CAUTION! Failure to follow operating instructions can compromise the user's safety.**

 **CAUTION! Unplug from power before cleaning. Do not immerse**

Parts Assembly List

To order parts for the ORBITAL-GENIE™ Shaker:

Contact your local distributor or visit www.scientificindustries.com. Please specify Part No., quantity and electric voltage.

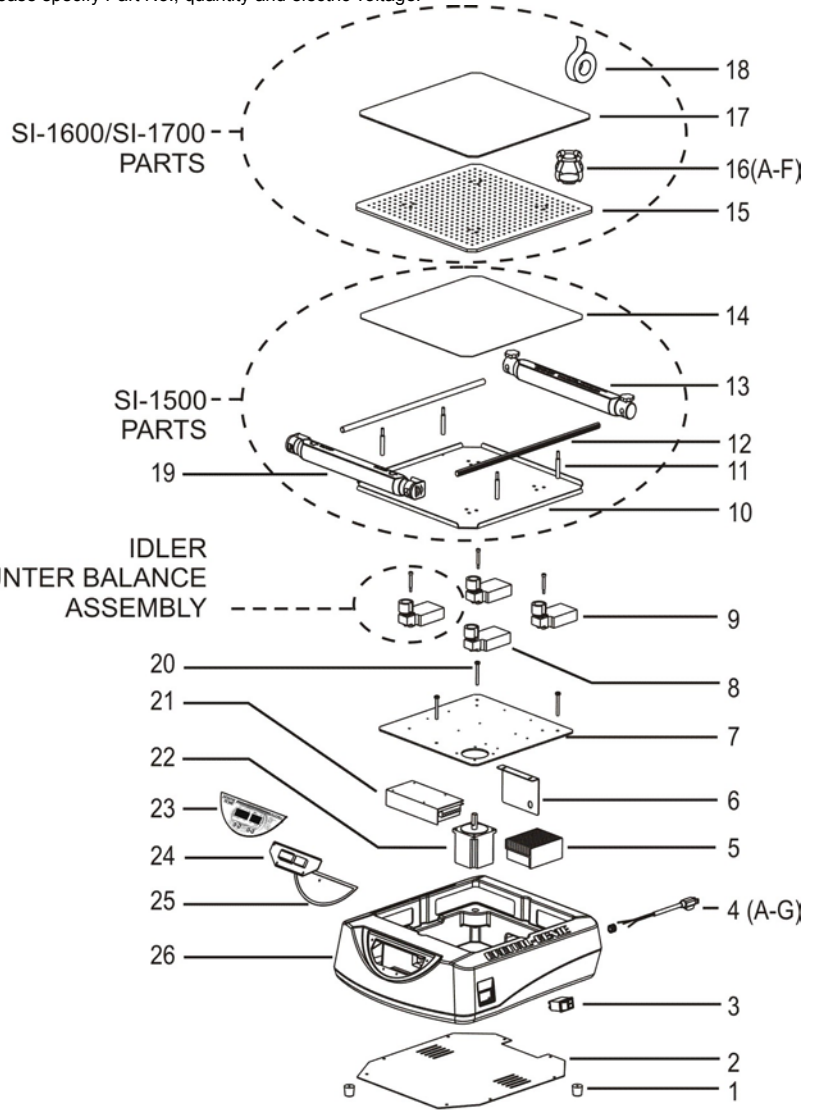
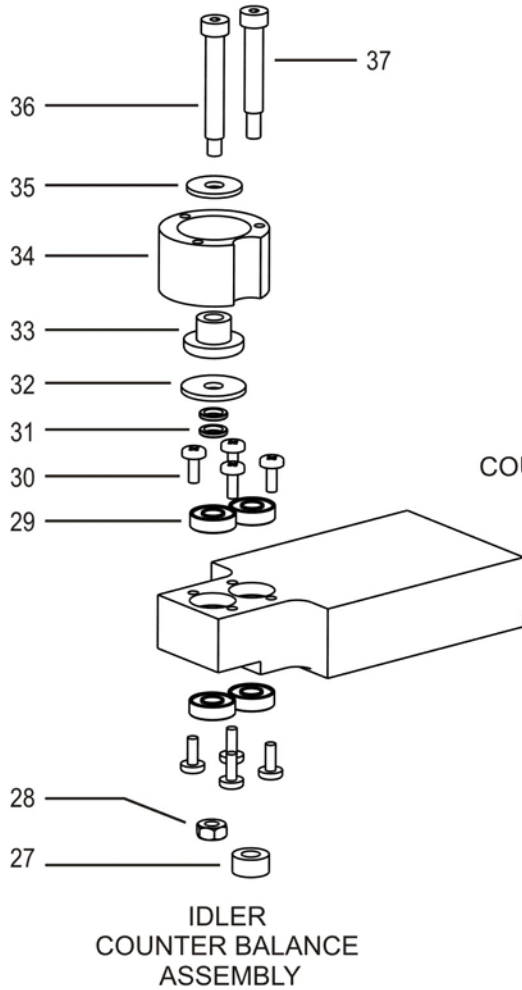

Item No	Part No.	Description
1	OK-1500-901	Feet (4)
2	OM-1500-200	Bottom Plate
3	ESP0006/ESP0007	Switch 100-120V/230V
4A	318-0510-02	120V Line Cord
4B	OK-0246-901	230V Line Cord, No Plug
4C	OK-0256-901	230V Line Cord, Euro Plug
4D	OK-0266-901	230V Line Cord, British Plug
4E	OK-0276-901	230V Line Cord, Swiss Plug
4F	OK-0286-901	100V Line Cord
4G	ECP0021	Australian Plug (plug only)
5	EPP0023	Power Supply
6	OM-1500-203	Label Bracket
7	OM-1500-202	Mounting Plate
8	OM-1500-207	Counter Balance, Motor
9	OM-1500-206	Counter Balance, Idler
10	OM-1500-204	Top Platform
11	OM-1500-215	Threaded Spacer
12	OM-1500-205	Rod, Ratchet
13	SI-1575	Non-ratcheting Clamp
14	OM-1500-214	Non-slip Rubber Pad
15	OM-1500-218	Flask Clamp Top Platform
16A	SI-1610	100mL Flask Clamp
16B	SI-1611	125/150mL Flask Clamp
16C	SI-1612	250mL Flask Clamp

Item No.	Part No.	Description
16D	SI-1613	500 mL Flask Clamp
16E	SI-1614	1 L Flask Clamp
16F	SI-1615	2 L Flask Clamp
17	SI-1617	Adhering Mat
18	SI-1616	Double Sided Adhesive
19	SI-1510	Universal Ratcheting Clamp
20	SCP0074	1/4-20 x 2 inch Screw
21	EMP0010	Driver, Motor
22	EMP0009	Stepper Motor
23	EL-1500-575	Keypad
24	EB-1500-500	Orbital PC Board
25	TPP0006	Gasket
26	PP-1500-400	Enclosure
27	HWP0076	1/4" Nylon Spacer
28	NTP0004	No. 10 Hex Nut
29	BRP001	Bearing
30	SCP0076	6-32 x 3/8" long screw
31	WAP0031	Washer
32	WAP0038	Special Flat Washer
33	HWP0075	Ribbed Bushing
34	OM-1500-208	Mounting Cup
35	WAP0037	Nylon Washer
36	SCP0077	Shoulder Screw, 1/4x 1 1/4
37	SCP0078	Shoulder Screw, 1/4x 1 1/2