

**QuadMag Genie®** is supplied with a non-skid pad for placing under the container to be stirred. This pad is useful for stabilizing the container but may not be necessary for certain applications.

**CAUTION!** Do not subject the **QuadMag Genie** to excessive shock. Dropping the unit, or otherwise subjecting it to unnecessary shock (ie: using excessive force to place vessels on the unit) may crack the case and lead to unsafe conditions.

**CAUTION!** Failure to follow operating instructions can compromise the user's safety.

#### Care and Handling

The **QuadMag Genie** should be given the care normally required for any electrical appliance. Avoid wetting or unnecessary exposure to fumes. The finish can be washed with a damp cloth (after unplugging) and soap or mild detergents, using a cloth or sponge. Keep the unit clean by immediately blotting any spills.

**CAUTION!** Unplug from power before cleaning. Do not immerse.

**CAUTION!** Do not use **QuadMag Genie** in hazardous atmospheres or with hazardous materials.

**CAUTION!** Do not use **QuadMag Genie** in applications such as mixing of flammable materials or where the transfer of mechanical energy to glass apparatus could lead to breakage.

#### TECHNICAL SPECIFICATIONS

The **QuadMag Genie** Magnetic Stirrer is classified as "Installation Category 2" Environmental: 0°C – 38°C (32°F-100°F), 95% Humidity max.

MODEL	POWER REQUIRED	AMPS
SI-4236	120V	0.65
SI-4246	230V, No Plug	0.5
SI-4256	230V, Euro Plug	0.5
SI-4266	230V, British Plug	0.5
SI-4276	230V, Swiss Plug	0.5
SI-4296	240V, Australian Plug	0.5
SI-4286	100V	1.0
SI-5236	120V	0.65
SI-5246	230V, No Plug	0.5
SI-5256	230V, Euro Plug	0.5
SI-5266	230V, British Plug	0.5
SI-5276	230V, Swiss Plug	0.5
SI-5296	240V, Australian Plug	0.5
SI-5286	100V	1.0



Weight: 3.0 Kg (6.6 lbs.)

Dimensions (DxWxH): 310x305x130mm (12.5x12.0x5.1in)

# QuadMag Genie®

## Four-Position Magnetic Stirrer Operating Instructions

Analog Models SI-4236 through SI-4296  
Digital Models SI-5236 through SI-5296



70 Orville Drive, Bohemia, NY 11716 U.S.A.

Phone: (631) 567-4700 • Fax: (631) 567-5896 Toll Free: 888-850-6208

Customer Service: [custsvc@scientificindustries.com](mailto:custsvc@scientificindustries.com)

[www.scientificindustries.com](http://www.scientificindustries.com)

The **QuadMag Genie**® is a powerful four-position magnetic stirrer that provides vigorous stirring for up to 4 vessels simultaneously. The **QuadMag Genie** is offered in Digital models with speed/time control and Analog models with speed control.

The **QuadMag Genie** is designed to safely and reliably mix liquid volumes up to 2 liters for each position, using powerful inert PTFE magnetic stirring bars (maximum stir bar length is 2"). The rugged housing is made with an engineering grade ABS/Polycarbonate thermoplastic resin. Timing belt driven pulleys rotate powerful rare earth magnets that stay coupled with the stirring bars even under the most demanding stirring conditions. Stirring speeds are infinitely variable from 250-1300 RPM (10 RPM increments for digital version) to facilitate gentle stirring up to full vortex mixing. The digital models have an opto-electronic software driven "ramp to speed" feature that ensures maximum coupling between drive magnet and stir bar (analog models require manual speed ramping). The enclosure is air cooled to prevent heat transfer to mixing media and is spill resistant to channel fluids away from internal components. Digital models have large LED's for displaying speed and time (0-99 min) or continuous.



## OPERATING INSTRUCTIONS

We recommend you retain the original packaging for 90 days in case you need to return the product for any reason to your distributor or Scientific Industries.

1.0 - Plug the line cord into a properly grounded electrical outlet. **(120 VAC for the SI-4236 and SI-5236 models; 230/240 VAC for the SI-4246 through SI-4276, SI-4296 models and SI-5246 through SI-5276, SI-5296 models; 100 VAC for the SI-4286 and SI-5286 models).** Illuminated ON/OFF switch (analog models) and illuminated numbers in the **TIME** and **SPEED** windows (digital models) indicate that the unit is ON and ready for use.

2.0 - The **QuadMag Genie Digital Models** have the following modes of operation:

### 2.1 – "TIMED" Operation

Allows for unattended operation that is timed from 1 to 99 minutes.

Press the **UP/DOWN** arrow buttons beneath the **TIME** window to set the desired stirring time. Press the **UP/DOWN** arrows beneath the **SPEED** window to set the desired stirring speed. Press the **START/STOP** button to begin the stirring action. The stirrer will ramp up to the desired speed and run until the set time has elapsed. To stop the cycle before the set time has elapsed, press the **START/STOP** button. To initiate a new timed cycle, press the **START/STOP** button again.

### 2.2 – "CONTINUOUS" Operation

Allows for continuous unattended operation.

Press the **UP/DOWN** arrow buttons beneath the **TIME** window and set stirring time to "0". Upon releasing the button, the display will have two dash marks (--), indicating that **no time limit** is set. Press the **UP/DOWN** arrows beneath the **SPEED** window to set the desired stirring speed. Press the **START/STOP** button to begin the stirring action. The stirrer will ramp up to the desired speed and run continuously. To stop the cycle, press the **START/STOP** button. To initiate a new continuous cycle, press the **START/STOP** button again.

### 2.3 - "SLEEP" Mode

The stirrer will automatically go into a "SLEEP" mode if the mixer is plugged in but not used for 10 minutes. The **TIME** and **SPEED** illuminated displays will go blank. Press the **START/STOP** button to "WAKE UP" the mixer.

*Note: The speed control can be adjusted up or down during the mixing cycle, however, the TIME can only be adjusted before the cycle begins.*

### 3.0 - QuadMag Genie® Analog Models

Allows for operation that will continue indefinitely until the unit is turned off.

Press the ON/OFF switch into the ON position. Adjust the SPEED potentiometer to the desired stirring speed. To ensure strong coupling between drive magnet and stir bar, it is recommended to manually ramp to maximum speed.

## PARTS ASSEMBLY LIST

To order parts for the **QuadMag Genie** - Contact your local distributor or visit [www.scientificindustries.com](http://www.scientificindustries.com). Please specify Part No., quantity and electric voltage.

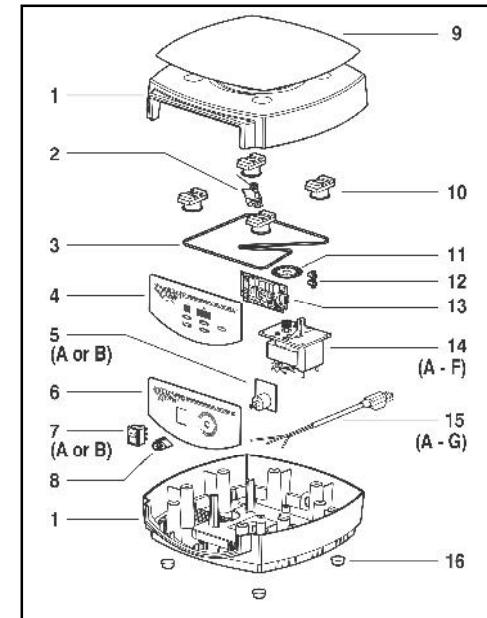

No	Part No.	Description	No	Part No.	Description
1	PP-2236-400	Housing, Top & Bottom Cover	14A	0K-4236-903	Motor 120V Assembly, Analog
2	0K-4236-904	Kit, Belt Tensioner	14B	0K-4246-903	Motor 230V assembly, Analog
3	HWP0060	Mat	14C	0K-4286-903	Motor 100V Assembly, Analog
4	0K-5236-900	Kit, Name Plate Assy, Digital	14D	0K-3236-903	Motor 120V Assembly, Digital
5A	EPP0005	Speed Control, 120V	14E	0K-3246-903	Motor 230V Assembly, Digital
5B	EB-0246-500	Speed Control, 230V	14F	0K-3286-903	Motor 100V Assembly, Digital
6	0K-4236-900	Kit, Name Plate Assy, Analog	15A	318-0510-02	120V Line Cord
7A	ESP0001	Rocker Switch, Red, 120V	15B	0K-0246-901	230V Line Cord, without Plug
7B	ESP0002	Rocker Switch, Green, 230V	15C	0K-0256-901	230V line cord, European Plug
8	0M-0236-209	Knob, Push-on	15D	0K-0266-901	230V Line cord, British Plug
9	0M-2236-207	Mat	15E	0K-0276-901	230V Line cord, Swiss Plug
10	0K-4236-901	Kit, Magnet Assembly	15F	0K-0286-901	100V Line cord
11	0K-2236-902	Optical Disc Assembly	15G	ECP0021	Australian Plug (only)
12	EC-A236-525	Optical Sensor	16	HWP0004	Feet
13	EB-5236-500	Digital Timer Board			